

Artificial Liver

- a personal update -

D.Falkenhagen

Department of Clinical Medicine and Biotechnology
Danube University Krems
Krems, Austria

Artificial liver: technology based on artificial materials developed for partial replacement of liver function

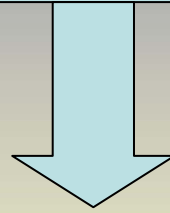

Better name: Artificial liver support system (ALSS)

Why: Partial Replacement?

Complex Liver functions:

- **Storage**
- **Synthesis**
- **Detoxification: Key-area for currently applied artificial liver support**
- **Immune modulation: Future field of artificial liver support**

Combined Extracorporeal Membrane-Adsorption Systems for Artificial Liver Support

Present stage

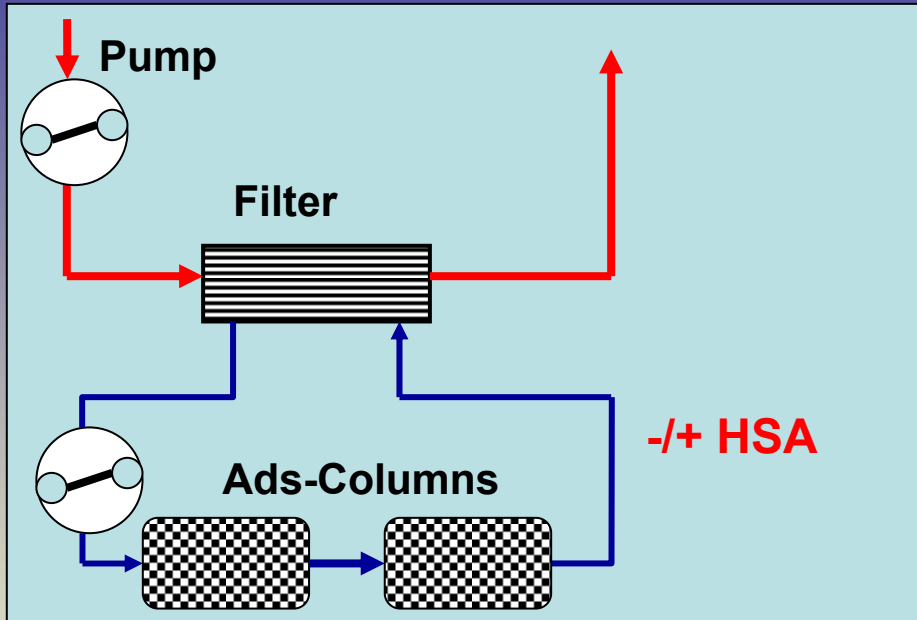

Column based Adsorption - Systems

- Prometheus/
- MARS

Future

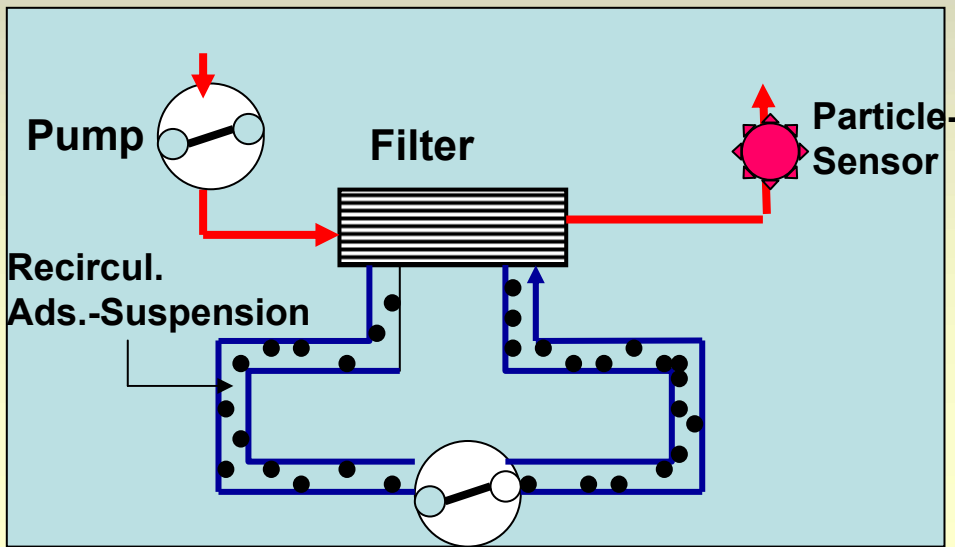

Suspension based Adsorption Systems

- Biologic DT System
- MDS-Technology

What substances have to be removed:

Protein (albumin-) bound substances

- Unconj. Bilirubin
- Aromatic amino acids
- Cholic acid

Hydrophobic (unbound) substances:

- Phenols
- Ammonia
- Mercaptans

Hydrophilic substances:

- GABA
- conj. Bilirubin
- Cytokines TNF-alpha, IL-6 ..

Additional:

- Uremic substances
- Endotoxins

But !!

**Acute Liver Failure
Is still
A Black Box**

Indications for liver support

- Acute liver failure
- **Acute on chronic liver failure**
- **Pruritus in case of hyperbilirubinemia**
- Primary graft non function

Red: Currently most important indications for ALLS

Bioartificial/artificial Liver Support

Principle Targets of Applications

- *Bridging to Tx*
- *Bridging to regeneration*

Commercially available artificial Liver Support Systems currently used clinically

- MARS (Gambro/Teraklin, ca 10 y)
- Prometheus (Fresenius Medical Care, ca 3y)



Principle of MARS

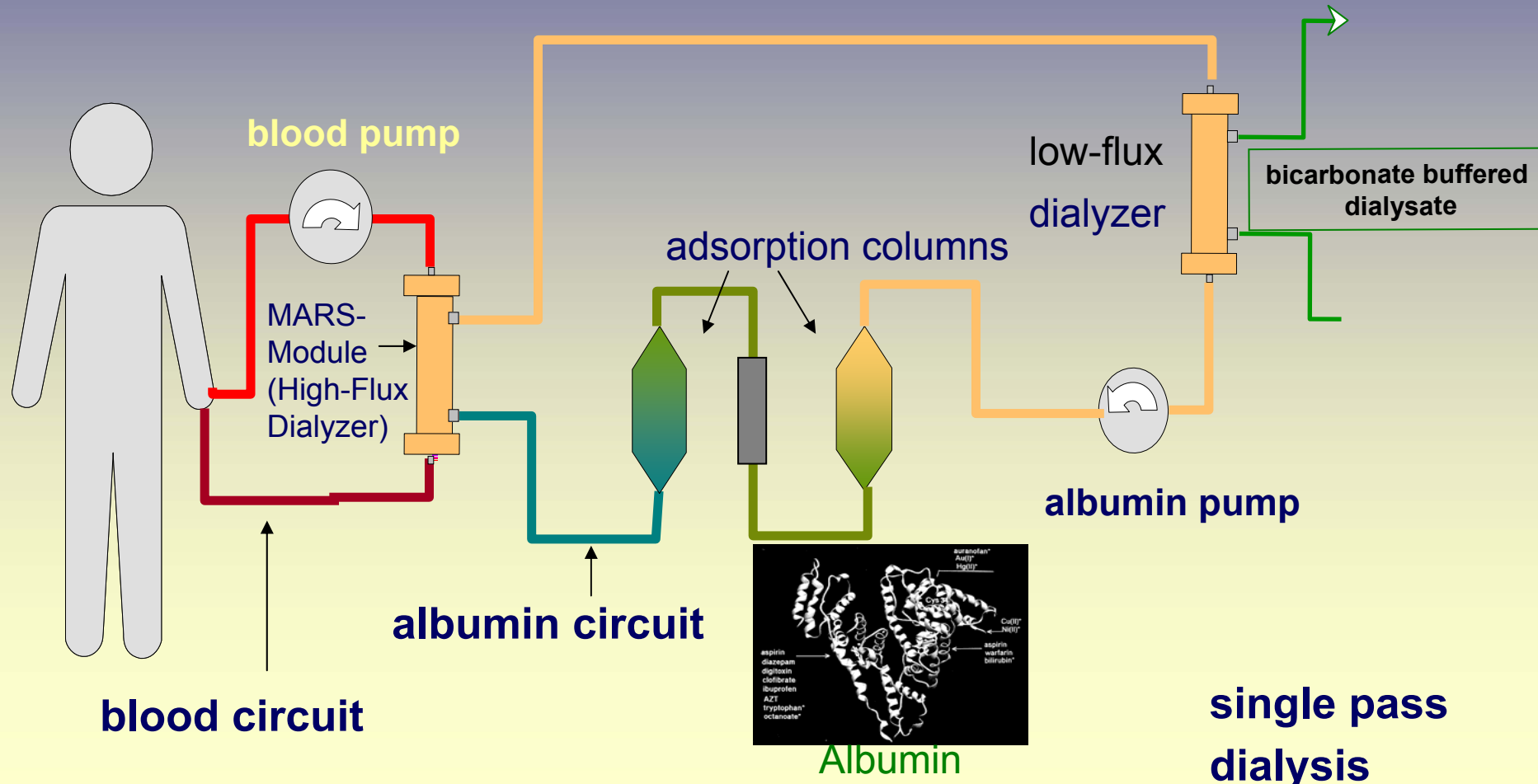

Prometheus™: Machine and Fluid Path

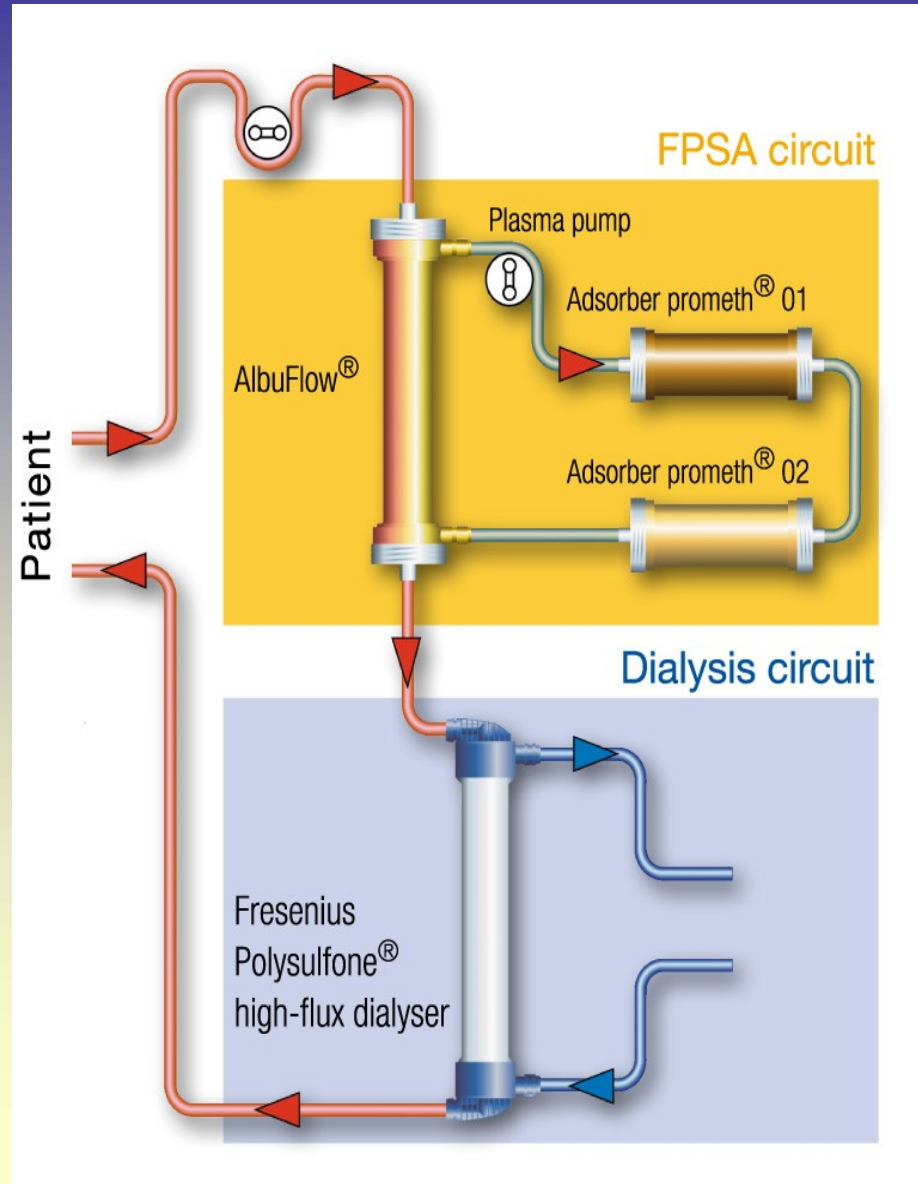

Direct vs. indirect adsorption

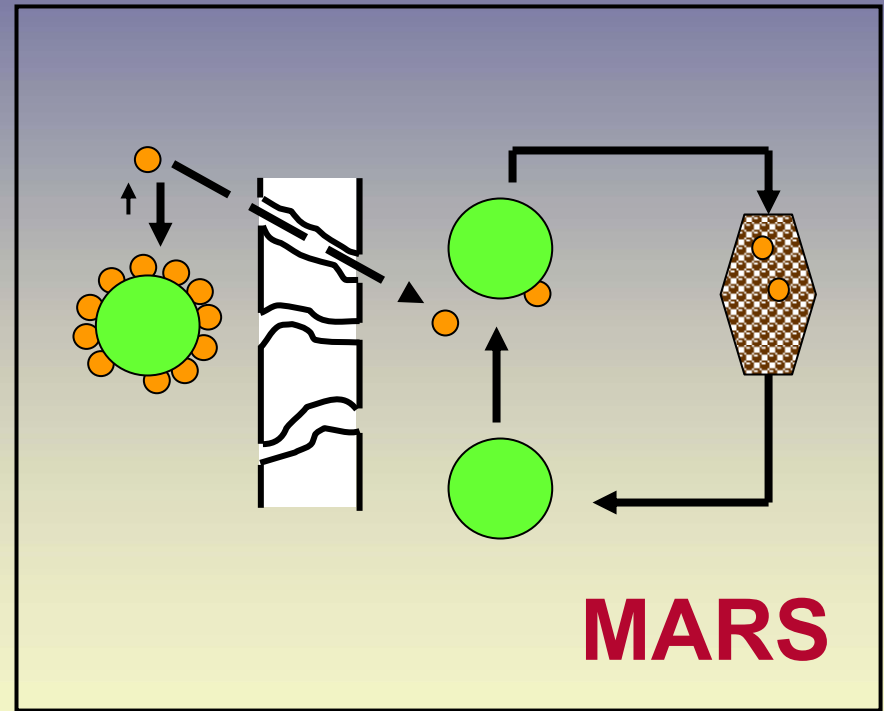
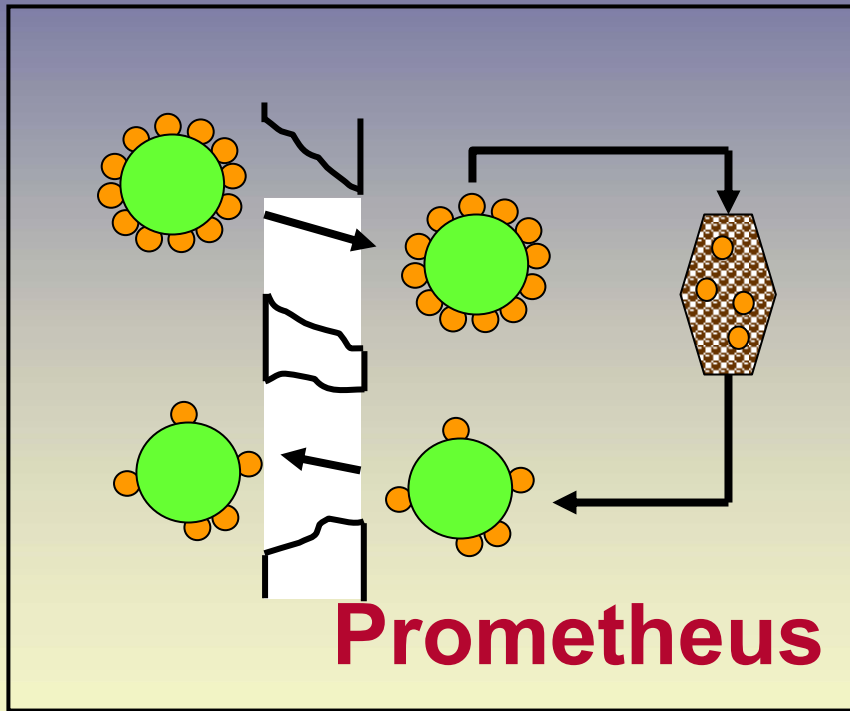

 Adsorbent column  Albumin  Bilirubin

Clinical Data

**MARS: About 6000 pts have been treated so far
7-8 Controlled randomized prospective
studies , multicentre study under way
(100 pts)**

**Prometheus: ca 1200 pts treated so far
Feasibility studies
Multicentre-Study (Helios: 150 pts)
under way**

The use of prospective randomized clinical studies are still the weak point !!

Global Future Market in Case of Successful Liver-Support

- Europe : 13 – 16.000 pts/year
- US/Canada : 10 – 12.000 pts/year
- Japan : 7 - 9.000 pts/year (reduced number of OLTx*)
- Rest (OECD-countries)
of the world: 20 – 25.000 pts/year

Total: 40 - 63.000 pts/year

Annual turnover: ca \$ 400-630 Mill consid. 5 treatments per patients to ca \$ 2000 per treatment using artificial systems

*OLTx (orthotopic liver transplantation)

These data are based on US-statistics: 150.000 liver-patients hospitalized per annum, 40.000 die per a. 25-30 % of these patients coming to death should make profit from an efficient liver support Therapy. Data for Europe, Japan and Rest of the world are an assessment from US-data

Future

- **Immune – Modulation**
(Removal of Cytokine inducing substances (endotoxins, cytokines))
- **higher Efficiency**
(especially for protein-bound substances such as unconj-bilirubin)
- **better blood compatibility**
(e.g. optimized citrate anticoagulation)

Microspheres Based Detoxification System

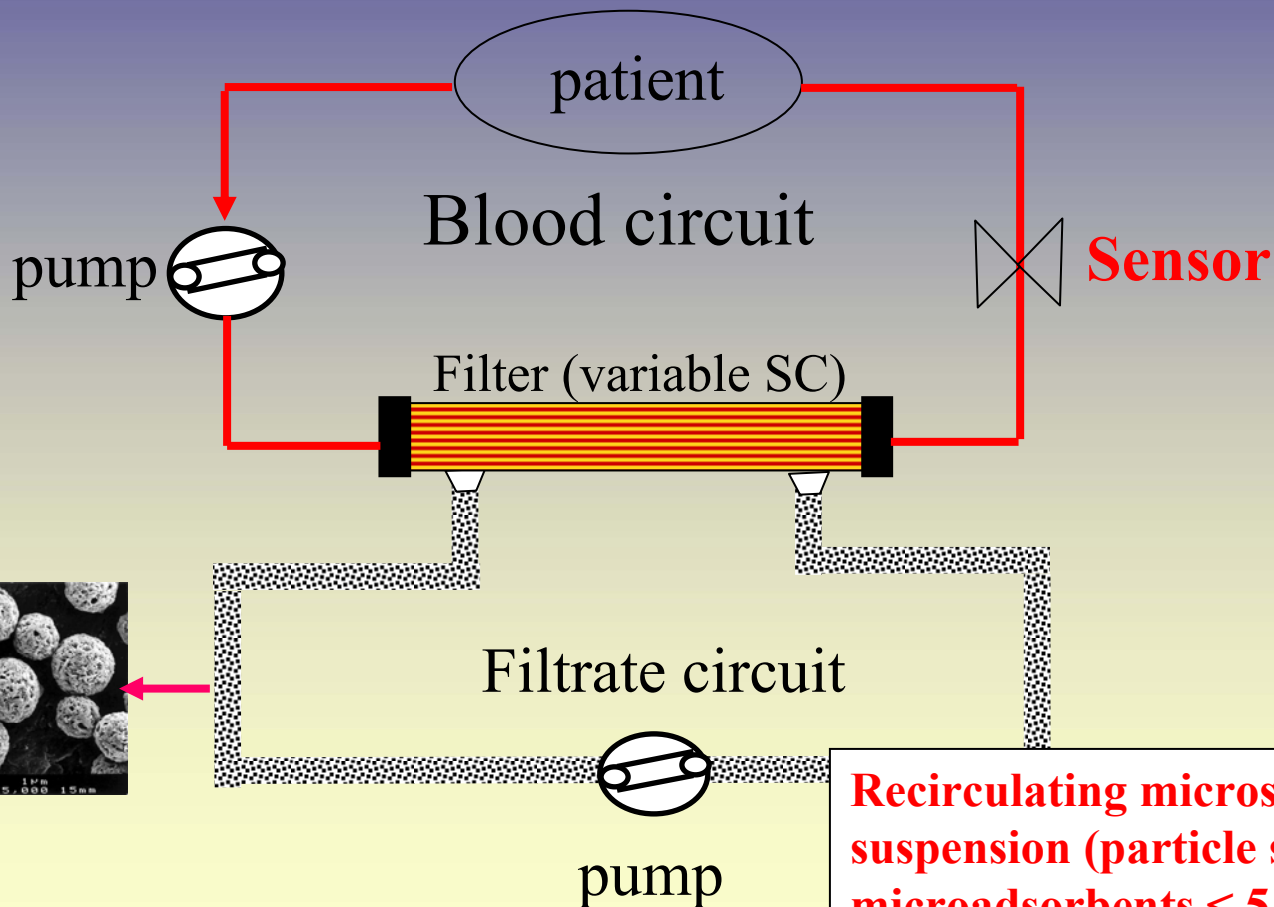

Recirculating microsphere suspension (particle size of microadsorbents $\leq 5 \mu\text{m}$!!!!) having a flow-rate of $>800/\text{min}$

Removal of liver failure-derived toxins by MDS

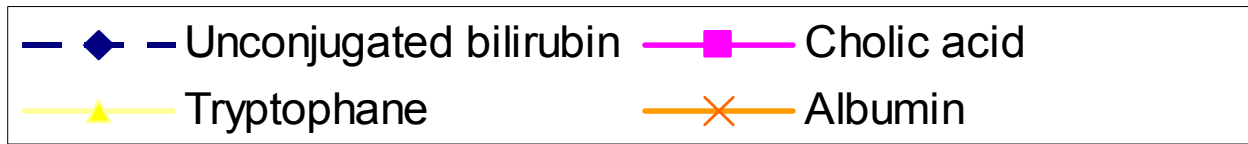
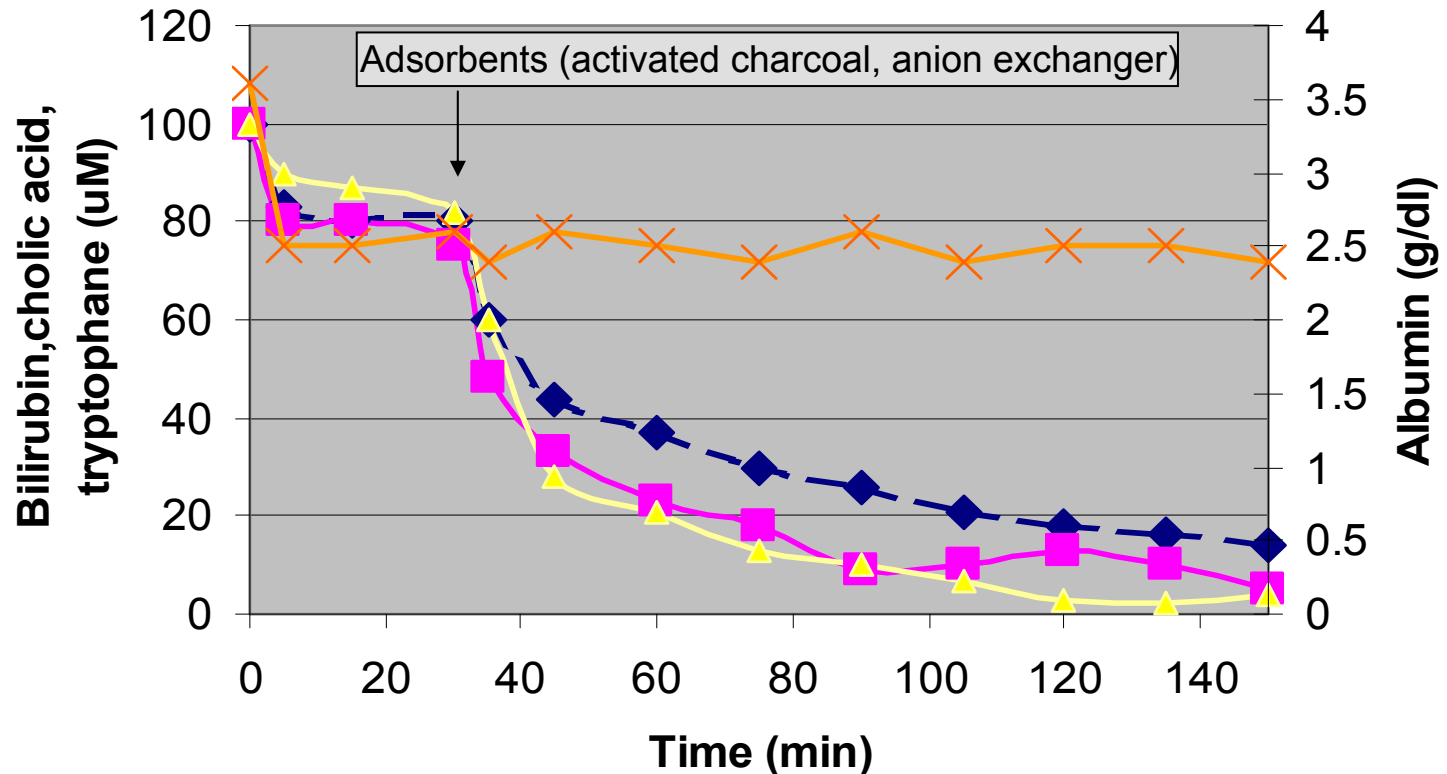

In vitro: 2l of spiked human plasma, 200ml/min flow rate, 8l/min secondary flow

Removal of IL-1 β , TNF- α and LPS by MDS

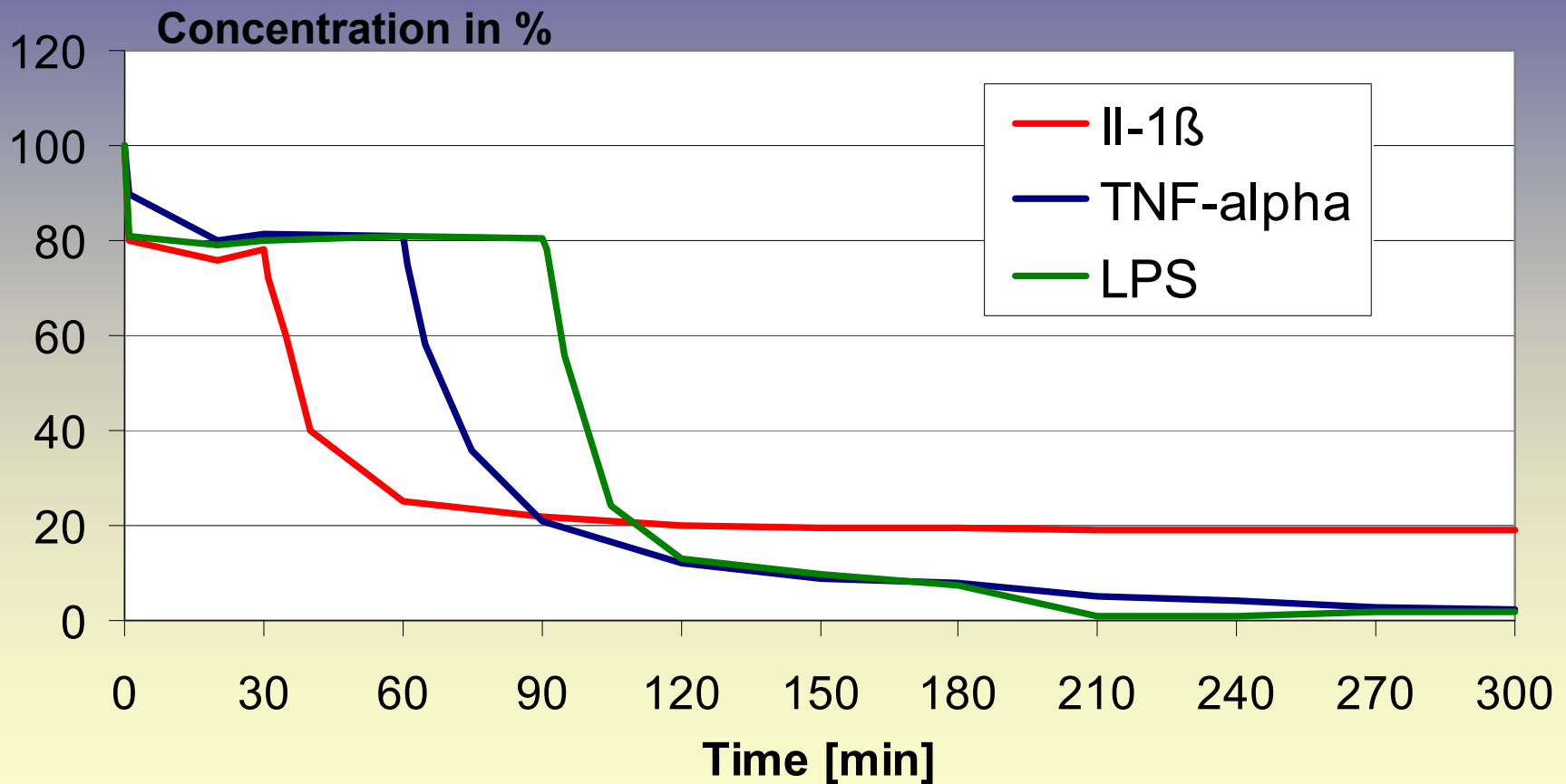

In vitro: 1 l human plasma spiked with 500 pg/ml IL-1 β , 500 pg/ml TNF- α and 1 ng/ml LPS:
Primary flow=200 ml/min, filtrate flow= 8 l/min

Conclusions

- The liver is a very complex internal organ which needs in case of loss of function complex support
- Currently used artificial liver **support systems (ALSS)** are mainly orientated to support the disturbed detoxification function including the removal of protein-bound substances such as unconjugated bilirubin
- Future ALSS will be designed to support also the diminished immune-function of the liver and will be much more efficient and biocompatible

**Aims of liver ICU
support:**

**Protecting the
brain**

**Gaining time for
growth &
Regeneration**

